

Honeywell

HRDE4X4
Digital Video
Recorder

User Guide

Revisions

Issue	Date	Revisions
1.00	09/05	New document.
2.00	03/06	Updated Remote Access Software sections with screenshots and function changes.
2.01	06/06	Corrected Alarm Out connection information.
3.00	07/06	Added PTZ function to RAS GUI. Added Sites menu in RAS.

FCC Compliance Statement

Information to the User: This equipment has been tested and found to comply with the limits for a Class A digital device. Pursuant to Part 15 of the FCC Rules, these limits are designed to provide reasonable protection against harmful interference when the equipment is operated in a commercial environment. This equipment generates, uses, and can radiate radio frequency energy and, if not installed and used in accordance with the instruction manual, may cause harmful interference to radio communications. Operation of this equipment in a residential area is likely to cause harmful interference in which case the user will be required to correct the interference at his own expense.

Caution Changes or modifications not expressly approved by the party responsible for compliance could void the user's authority to operate the equipment.

This Class A digital apparatus complies with Canadian ICES-003.

Cet appareil numérique de la Classe A est conforme à norme NMB-003 du Canada.



Explanation of Graphical Symbols



This symbol indicates the presence of uninsulated "dangerous voltage" within the product's enclosure that may be of sufficient magnitude to constitute a risk of electric shock to persons.



This symbol indicates the presence of important operating and maintenance (servicing) instruction in the literature accompanying the product.

	CAUTION RISK OF ELECTRIC SHOCK DO NOT OPEN	
CAUTION: TO REDUCE THE RISK OF ELECTRIC SHOCK, DO NOT REMOVE THE COVER (OR BACK). NO USER-SERVICEABLE PARTS INSIDE. REFER SERVICING TO QUALIFIED SERVICE PERSONNEL.		

Warnings

Installation and servicing should be performed only by qualified and experienced personnel.

Power off the DVR when connecting cameras, audio, or sensor cables.

The manufacturer is not responsible for any damage caused by improper use of the product or failure to follow instructions for the product.

The manufacturer is not responsible for any problems caused by or resulting from the user physically opening the DVR for examination or attempting to fix the unit. The manufacturer may not be held liable for any issues with the unit if the warranty seal is removed.

Cautions

This product has multiple-rated voltages (110V and 220V). See installation instructions before connecting to the power supply.

This product uses a Lithium battery. To avoid a risk of explosion, do not replace the battery on the main board by anything other than a Lithium battery. Dispose of used batteries according to the manufacturer's instructions.

This equipment and all communication wirings are intended for indoor use only. To reduce the risk of fire or electric shock, do not expose the unit to rain or moisture.

WEEE (Waste Electrical and Electronic Equipment)

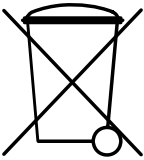

Customers in European Union countries are advised to dispose of this product, at the end of its useful life, as per applicable local laws, regulations and procedures.

Contents

1	Introduction	1
	Features	1
	Technical Overview	1
	Important Safeguards	2
	Lithium Battery	4
2	DVR Unit Installation	5
	Before You Begin	5
	Unpack Everything	5
	Typical DVR Installation	6
	Setting Unit for NTSC or PAL	6
	Connecting Peripheral Equipment	7
	Connecting the Power Cord	9
	UPS	9
3	DVR Configuration	11
	Front Panel LEDs and Controls	11
	USB Port	12
	Initial Setup	13
	Menu Structure	13
	Live Mode	14
	Recording Mode	15
	Motion Zones	16
	Recording Schedules	17
	Setting System Parameters	17
	Controlling a PTZ Camera	20
	Setting Network Parameters	21
	Setup Sending E-Mail Reports	24
	Storage Setup	25
	Saving Setup	25
4	Front Panel Operation	27
	Live Viewing Window	27
	Search Window	28
	Time-Line Search	30
	Go To Search	31
	Go First Search	32
	Go Last Search	32
	Log List Search	32
	Archive Search	33
	Play Mode	34
	Network Mode	35
	Archiving Video	36
	Archiving Still Images onto USB	36
	Archiving Video onto USB	36
	Transferring Still Images or Video onto USB	37

5	RAS Installation	39
	Minimum PC Requirements	39
	Installing the RAS Program	39
6	RAS Operation	43
	Live Viewing	43
	Live Viewing Interface	43
	Search and Playback Viewing	46
	Search and Playback Interface	46
	Back Up a Video Clip in AVI Format	48
7	RAS Configuration	51
	General Setup	51
	Site Setup	52
	Event Setup	53
	Event Search Setup	53
	Record Menu	54
	Disk Menu	55
	Video Menu	55
	About Menu	56
Appendix A	DVR Firmware Upgrade	57
	1. Copy Firmware Upgrade to USB Stick	57
	2. Start Engineering Mode	57
	3. Upgrading Using USB Stick	58
	4. Verifying Software Installation	58
Appendix B	Playing AVI Archive Clips	59
Appendix C	Optional Items	61
	Remote Control Operation	61
	Configuring Multiple Units for Remote Control	62
Appendix D	Specifications	63

Introduction

Features

Your HRDE4X4 digital video recorder (referred to as DVR throughout this document) is a stand-alone and/or networked video and audio recording device. It provides recording capabilities for four camera-inputs and is capable of event, pre-event, or timelapse recording. The DVR can function in semi-triplex mode; that is, you can play back video while simultaneously recording in a network configuration. Each of the four channels can record independently or simultaneously. Other features include:

- 4 composite input connectors
- NTSC or PAL configuration
- Records up to 30 NTSC images per second or 25 PAL images per second (IPS). The total frame rate is 120 IPS in quad screen and 30 IPS in full screen mode.
- Video resolution (display and recording):
 - Full screen mode — 720 x 480 NTSC, 720 x 576 PAL
 - Quad mode — 360 x 240 NTSC, 360 x 288 PAL
- Recording modes — manual, schedule, alarm events, time events and motion events.
- MPEG-4 video compression to maximize storage and video streaming on the internet.
- The Remote Access Software (RAS) supports remote live viewing, PTZ control, searching, archiving, and video playback. By installing the DVR remote software on a Microsoft Windows[®] PC you can monitor real-time and recorded video via an optional ethernet network.
- USB archiving function provides storage for still images and AVI clips.
- The Remote Access Software allows playback of video clips archived to a USB stick without first transferring the data to the local PC hard drive.
- Operates on a real-time, embedded RTOS operating system with a user-friendly Graphic User Interface (GUI).
- Built-in front panel and remote pan, tilt, zoom (PTZ) controller
- 3 simultaneous remote users performing live view or playback on the same DVR

Technical Overview

Your HRDE4X4 DVR incorporates a switcher and multiplexer for selectable multi-mode display, digital motion detection, camera tiling, and event, pre-event, or timelapse recording.

The DVR converts analog NTSC or PAL video to digital images and records them on one hard drive. You can access recorded video from the hard drive or previously archived video from a USB stick. You can watch live video while simultaneously recording.

The Remote Access Software allows the administrator to remotely connect to and monitor up to 512 networked DVRs. The software logs the operational and alarm status of sites once a day for later analysis. The software lets you search based on time and retrieve video clips from remote sites.

Important Safeguards

1. **Read Instructions**
All safety and operating instructions should be read before the appliance is operated.
2. **Retain Instructions**
The safety and operating instructions should be retained for future reference.
3. **Cleaning**
Unplug this equipment from the wall outlet before cleaning it. Do not use liquid aerosol cleaners. Use a damp soft cloth for cleaning.
4. **Attachments**
Never add any attachments and/or equipment without manufacturer approval as such additions may result in the risk of fire, electric shock, or other personal injury.
5. **Water and/or Moisture**
Do not use this equipment near water or in contact with water.
6. **Accessories**
Do not place this equipment on an unstable cart, stand, or table. The equipment may fall, causing serious injury to a child or adult, and serious damage to the equipment. Wall or shelf mounting should follow the manufacturer's instructions, and should use a mounting kit approved by the manufacturer.



Move this equipment and cart combination with care. Quick stops, excessive force, and uneven surfaces may cause the equipment and cart combination to overturn.

7. **Power Sources**
This equipment should be operated only from the type of power source indicated on the marking label. If you are not sure of the type of power, please consult your equipment dealer or local power company.
If you are having problems with your power supply and need to replace it, contact Honeywell (see the back cover for contact information) and order the HRDE4X4 DVR power supply, model number HRDE4PS. Only use this power supply with your HRDE4X4 DVR.
8. **Power Cords**
Operator or installer must remove power, BNC, alarm, and other connections before moving the equipment.
9. **Lightning**
For added protection for this equipment during a lightning storm, or when it is left unattended and unused for long periods of time, unplug it from the wall outlet and disconnect the antenna or cable system. This will prevent damage to the equipment due to lightning and power-line surges.
10. **Overloading**
Do not overload wall outlets and extension cords to avoid the risk of fire or electric shock.

11. Objects and Liquids

Never push objects of any kind through openings of this equipment as they may touch dangerous voltage points or short out parts that could result in a fire or electric shock. Never spill liquid of any kind on the equipment.

12. Servicing

Do not attempt to service this equipment yourself. Refer all servicing to qualified service personnel.

13. Damage Requiring Service

Unplug this equipment from the wall outlet and refer servicing to qualified service personnel under the following conditions:

- When the power-supply cord or the plug has been damaged
- If liquid is spilled or objects have fallen into the equipment
- If the equipment has been exposed to rain or water
- If the equipment does not operate normally by following the operating instructions, adjust only those controls that are covered by the operating instructions as an improper adjustment of other controls may result in damage and will often require extensive work by a qualified technician to restore the equipment to its normal operation.
- If the equipment has been dropped or the cabinet damaged
- When the equipment exhibits a distinct change in performance—this indicates a need for service.

14. Replacement Parts

When replacement parts are required, ensure the service technician uses replacement parts specified by the manufacturer or that have the same characteristics as the original part. Unauthorized substitutions may result in fire, electric shock, or other hazards.

15. Safety Check

Upon completion of any service or repairs to this equipment, ask the service technician to perform safety checks to determine that the equipment is in proper operating condition.

16. Field Installation

This installation should be made by a qualified service person and should conform to all local codes.

17. Correct Batteries

WARNING! **Risk of explosion if battery is replaced by an incorrect type.
Dispose of used batteries according to the instructions.**

18. Operating Temperature

An operating temperature range is specified (see *Appendix D, Specifications*) so that the customer and installer may determine a suitable operating environment for the equipment.

19. Elevated Operating Ambient Temperature

If installed in a closed or multi-unit rack assembly, the operating ambient temperature of the rack environment may be greater than room ambient. Therefore, consideration should be given to installing the equipment in an environment compatible with the specified operating temperature range.

20. Reduced Air Flow

Installation of the equipment in the rack should be such that the amount of airflow required for safe operation of the equipment is not compromised.

21. Mechanical Loading

Mounting of the equipment in the rack should be such that a hazardous condition is not caused by uneven mechanical loading.

22. Circuit Overloading

Consideration should be given to connection of the equipment to supply circuit and the effect that overloading of circuits might have on over-current protection and supply wiring. Appropriate consideration of equipment nameplate ratings should be used when addressing this concern.

23. Reliable Earthing (Grounding)

Reliable grounding of rack mounted equipment should be maintained. Particular attention should be given to supply connections other than direct connections to the branch circuit (for example, use of power strips).

Lithium Battery

The unit contains a single 3 VDC lithium battery. This battery is used to maintain the real-time clock of the unit. When power is not applied to the unit, the battery is used to maintain the clock and retain the correct clock setting by the installer. After several years of operation, it may become necessary to replace this battery. If the battery fails, the unit clock will reset to 2001-01, 01 00:00:00. Contact Honeywell Technical Support for assistance with this. The old battery should be discarded at an appropriate waste site for lithium batteries as per local guidelines in your area.

2

DVR Unit Installation

This chapter covers how to:

- Set the DVR for NTSC or PAL
- Connect the DVR to peripheral equipment

Before You Begin

Please read this document carefully before you install your DVR.
Keep this guide for future reference.

Unpack Everything

Check that the items received match those listed on the order form and packing slip. The HRDE4X4 packing box should include:

- One fully-assembled HRDE4X4 DVR
- One power cable
- One 12 VDC switching adapter
- One Remote Access Software CD
- This User's Guide

If any parts are missing or damaged, contact the dealer you purchased the DVR from or call Honeywell Customer Service (see the back cover of this document for contact information).

Typical DVR Installation

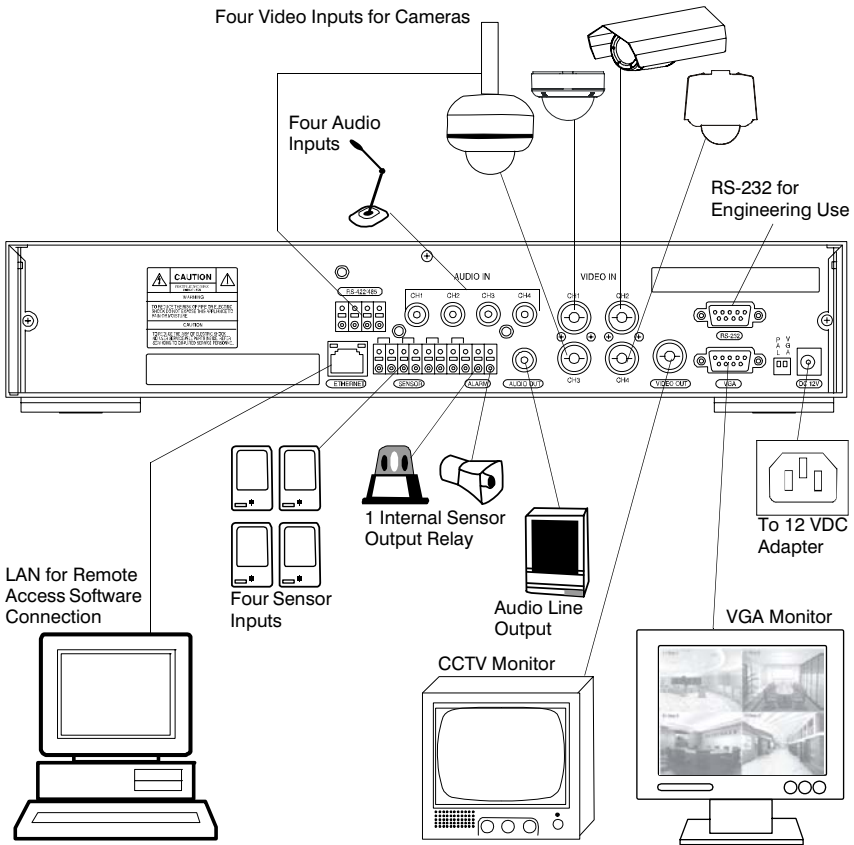

Setting Unit for NTSC or PAL

Before turning on your DVR, set the switch (see [Figure 2-1](#)) to NTSC or PAL to match your equipment. If your DVR is already powered, unplug the power cord from the wall outlet. Wait a few seconds, set the switch (see [Figure 2-1](#)), and then re-apply power.

Note You cannot mix NTSC and PAL equipment. For example, do not connect NTSC cameras when your DVR is set to PAL. Similarly, do not connect a PAL camera and an NTSC monitor.

Figure 2-1 NTSC/PAL Operation Switch

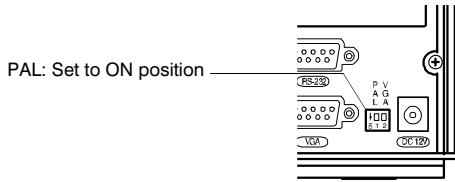

Connecting Peripheral Equipment

Figure 2-2 shows the rear panel connections. Refer to Table 2-1 to connect your network system components.

Figure 2-2 Rear Panel Connections

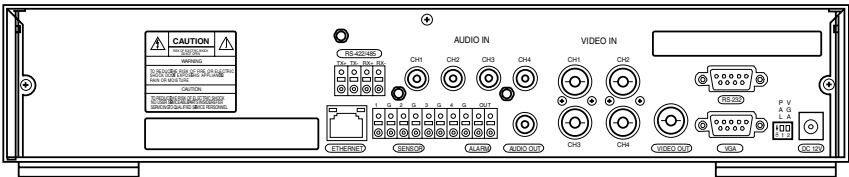

Table 2-1 describes the rear panel connections as shown in Figure 2-2 from left to right.

Table 2-1 Rear Panel Connections

Connector	Description
RS-422/485	Remote camera control (see <i>Controlling a PTZ Camera</i> , page 20).
ETHERNET	Network the DVR using 10/100 MB Ethernet connector. Network to a PC for remote monitoring and searching (see <i>Setting Network Parameters</i> , page 27).
AUDIO IN	Connect to a pre-amplified line level audio source, such as a microphone. Must not exceed 3 m. Note It is the user's responsibility to determine if the local laws and regulations permit recording audio.
AUDIO OUT	Connect to an amplifier. Must not exceed 3 m.

Table 2-1 Rear Panel Connections (Cont'd)

Connector	Description
SENSOR IN	<p>Connect to external alarm sensor devices to signal the DVR to react to events. Four sensors can be connected to the equipment sensor 1–4 dedicated to Video channel 1–4 respectively. Simple On/Off switching of sensor inputs 1–4, normal open (NO) and ground connected to input starts recording or normal close (NC) and ground connected to input stops recording (see <i>Recording Mode</i>, page 15 to program sensor recording).</p> <p>Connect two wires to operate a sensor input correctly to the Terminal block on the rear panel of the HRDE4X4. One ground wire between the external device and to the HRDE4X4 ensures the ground reference voltage is identical. This line connects to the terminal block G input. Connect the other wire to be used to trigger the record condition to the sensor input 1–4 connection on the terminal block.</p> <p>Sensor Input Connections</p>
ALARM OUT	<p>An internal relay will connect/close the two external alarm output terminals connecting one to the other. The relay can be triggered to close the two alarm connections by either motion or a sensor input, if enabled in the Recording Setup menu. This can be used to turn on or off an external buzzer or light. Whether the alarm contacts are Open or Closed depends on the setting of NO (normally open) or NC (normally closed) in the record screen (Rated load 0.5 A @ 30 VAC or 1 A @ 30 VDC).</p> <p>Set to NO: Contacts are open until triggered to close Set to NC: Contacts are closed until triggered to open</p>
VIDEO IN	<p>Connect NTSC or PAL camera coaxial outputs (up to 4) to the BNC Video In connectors.</p> <p>Caution Do not mix NTSC and PAL cameras.</p>
VIDEO OUT	Connect to a monitor.
RS-232	For engineering use only.
VGA	<p>Connect to a VGA monitor. Must not exceed 3 m.</p> <p>Note When using a VGA monitor, make sure you set the VGA switch to ON and power reset the unit (turn unit off then on).</p>

Table 2-1 Rear Panel Connections (Cont'd)

Connector	Description
SWITCHES	
PAL	Set to the ON position when PAL cameras are connected. Note When you change the position of the PAL switch, reboot the DVR to apply the new setting.
VGA	Set to the ON position when a VGA monitor is connected. Note When you change the position of the VGA switch, reboot the DVR to apply the new setting. When VGA is enabled, the video out connector (composite) is disabled. Also when the Video Out is enabled, the VGA is disabled.
DC 12V	Apply 12 VDC using the DC switching adapter supplied.

Connecting the Power Cord

1. Connect the DC power cord of the adapter to the DVR.
2. Connect the AC power cord to the adapter and then to the wall outlet.

Your DVR is now ready to operate. See *Chapter 3, DVR Configuration* and *Chapter 4, Front Panel Operation* for more information.

WARNING! Route power cords so they are not a tripping hazard. Make certain the power cord will not be pinched or abraded by furniture. Do not install power cords under rugs or carpet.

The power cord has a grounding pin. If your power outlet does not have a grounding pin receptacle, do not modify the plug.

Do not overload the circuit by plugging too many devices into one circuit.

UPS

It is highly recommended that the HRDE4X4 be connected to an interrupted Power supply (UPS). This provides temporary backup power to operate the unit with during a limited power outage. The UPS will also protect the unit from AC power fluctuations and power spikes from the power grid. Use of a UPS will protect your investment in your HRDE4x4.

DVR Configuration

This chapter covers:

- Front panel LEDs and controls
- Initial DVR setup
- Configuring live and recording modes
- Setting motion zones
- Setting recording schedules
- Setting system parameters
- Configuring remote network control
- Setting storage parameters

Note Ensure that your DVR is completely installed and all components are connected before proceeding.

Front Panel LEDs and Controls

Figure 3-1 shows the front panel and *Table 3-1* and *Table 3-2* describe the operational LEDs and control buttons.

Figure 3-1 Front Panel

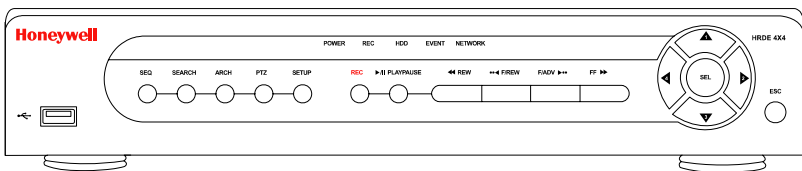







Table 3-1 Front Panel LEDs

LED	Function
POWER	ON indicates power is applied to the unit.
REC	ON indicates recording is enabled.
HDD	ON indicates the system is accessing the hard drive.
EVENT	ON indicates the alarm sensor(s) has/have been triggered or motion is detected.
NETWORK	ON indicates a user is connected to the system through the RAS software.

Table 3-2 Front Panel Controls

Control	Function
SEQ	Start auto sequencing (must be in full screen mode). Toggles on and off.
SEARCH	Opens search menu.
REC	Starts/stops manual recording (requires password entry).
ARCH	Starts archiving a video clip or still image to a USB stick.
PTZ	Controls Pan/Tilt/Zoom (PTZ) operation.
SETUP	Opens the Setup menu.
ESC	<ul style="list-style-type: none"> Temporarily stores the changed value Returns to the previous menu screen
◀◀ REW	<ul style="list-style-type: none"> Rewinds the video in Playback mode. Press again to toggle the playback speed at 1x, 2x, 4x, 8x and 16x speeds. See the LOG LIST.
••◀ F/REV	Jump/step backward. In Playback mode, the playback position moves one minute backward.
▶/ PLAY/PAUSE	Play or pause a video clip in Playback mode.
F/ADJ ▶••	Jump/step forward. In Playback mode, the playback position moves one minute forward.
FF ▶▶	<ul style="list-style-type: none"> Plays the video forward in Playback mode. Press again to toggle the speed at 1x, 2x, 4x, 8x and 16x speeds. See the ARCHIVE LIST.
	<ul style="list-style-type: none"> Moves up in the menu structure in Setup mode Selects camera 1 in Live and Playback modes Used as the number 1 when entering the password
	<ul style="list-style-type: none"> Moves right in the menu structure in Setup mode Selects camera 2 in Live and Playback modes Used as the number 2 when entering the password
	<ul style="list-style-type: none"> Moves down in the menu structure in Setup mode Selects camera 3 in Live and Playback modes Used as the number 3 when entering the password
	<ul style="list-style-type: none"> Moves left in the menu structure in Setup mode Selects camera 4 in Live and Playback modes Used as the number 4 when entering the password
	<ul style="list-style-type: none"> Selects full screen or quad view in Live and Playback modes Selects desired menu item Stores setup value in the menu

USB Port

There is a USB port on the left side of the front panel. You can use this port to archive video onto a USB stick (see [Archiving Video](#), page 36) and to upgrade the DVR firmware.

Initial Setup

Before using your DVR for the first time, you should establish some initial settings (for example, date and time, display language, camera settings, recording mode and scheduling, and your network setup). The following sections describe how to use the Setup menu to quickly set up your DVR.

1. Press **SETUP** on the front panel to enter the Setup menu.
2. At the prompt, enter your password using the appropriate combination of arrow buttons. The default password is **1111**. Press **SEL** to enter the password.
3. After the password is entered you will see the main **Setup** menu screen as shown in *Figure 3-2*. Use the arrow buttons to navigate through the menu items. Press **SEL** to enter the desired sub-menu.

We recommend that you protect your DVR system by assigning a new password immediately. Please follow the procedure in *Setting System Parameters*, page 17.

Figure 3-2 Setup Menu Screen



Menu Structure

The **Setup** menu structure is as follows:

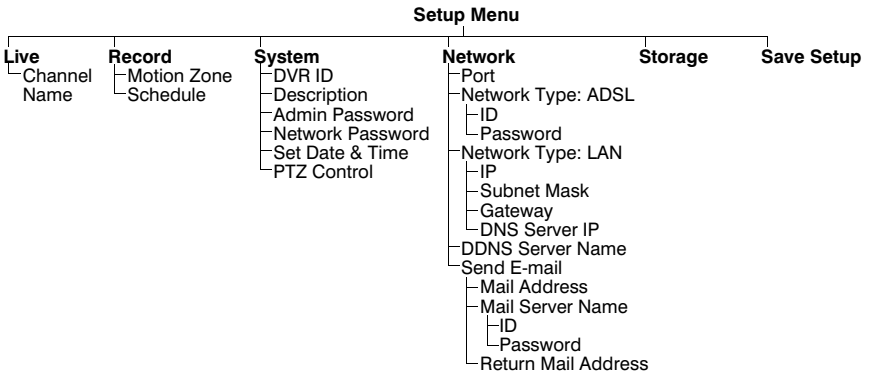

Live Mode

To set values for live video display, use the **UP** and **DOWN** controls to navigate through the menu items. Change the value of the menu item using the **LEFT** and **RIGHT** controls.

Figure 3-3 Live Mode Setup Screen



Follow [Table 3-3](#) to set the Live Mode parameters.

Table 3-3 Live Mode Setup Fields

Field	Description
OSD	Enable/disable on-screen display.
SEQUENCE	Enable/disable sequential display of video in Full Screen mode.
SEQ-DWELL TIME	Set the Dwell time for each channel display in Sequential Display mode (choose from 1–60 seconds).
SCREEN CROPPING	Enable/disable cropping to make the display fit the screen.
TRANSPARENT	Change the transparency level of the on-screen display.
CHANNEL	Select the channel (camera 1–4) for applying the six following settings. Any changes you make will immediately take effect with the selected channel. Press SEL to enter a text insertion screen and apply a new name for the channel. Use the LEFT and RIGHT arrow controls to navigate through the channel name and the UP and DOWN arrow controls to change the selected character. Press SEL to confirm the name.
DISPLAY	Enable/disable display of the video channel in Live Display mode.
SEQ LIST	Enable/disable the specified channel to be included in the Sequential Display mode.
BRIGHTNESS	Change the brightness value for the specified channel.
CONTRAST	Change the contrast value for the specified channel.
HUE	Change the hue value for the specified channel.
SATURATION	Change the saturation value for the specified channel.

Recording Mode

To set values for recording video, use the **UP** and **DOWN** controls to navigate through the menu items. Change the value of the menu item using the **LEFT** and **RIGHT** controls.

Figure 3-4 Recording Mode Setup Screen



Follow [Table 3-4](#) to set the Recording Mode parameters.

Table 3-4 Recording Mode Setup Fields

Field	Description
RESOLUTION	Set the resolution to either FULL Screen or QUAD View.
CHANNEL	Select the channel (camera 1–4) to apply the following settings on. Changes you make will immediately take effect with the selected channel.
FRAME RATE	Set the frame rate for the specified channel (choose from OFF or 1–30 fps). The sum of the frame rate values from each channel cannot exceed the maximum frame rates for a specific recording resolution. The total Maximum frame rate for NTSC video are 120 Fps (frames per second) for Quad and 30 Fps for Full.
QUALITY	Select the recording quality for the specified channel. Options are: NORMAL HIGH SUPER
RECORDING	Assign the recording mode for each channel. Options are: CONTINUOUS BY MOTION BY SENSOR (record based on sensor inputs) BY SCHEDULE DISABLE
MOTION ZONE	Select motion sensing zones. Options are: FULL ZONE PARTIAL ZONE Note If Partial Zone is selected (press SEL), the screen will change as shown in Figure 3-5 .
MOTION SENSITIVITY	Set the motion sensitivity for the specified channel, from: 1 to 9 (where 9 is the most sensitive setting)

Table 3-4 Recording Mode Setup Fields (Cont'd)

Field	Description
SENSOR TYPE	Set the type of sensor for the specified channel (see SENSOR IN on page 8 for connection information). Options are: None N/O normal open (ground connected to the input starts recording) N/C normal closed (ground connected to the input stops recording)
PRE RECORD	Enable/disable pre-event recording. Pre-event recording time is five seconds and only intra-frames are recorded for pre-event recording.
POST EVENT RECORD	Set post event recording time duration for the specified channel (choose from 2–30 seconds).
ALARM	Enable/disable alarm output for the specified channel. The sensor output relay can be closed by either a motion event or a sensor input, if enabled.
ALARM DURATION	Set the alarm time duration for the specified channel (choose from 1–60 seconds).
AUDIO	Enable/disable audio recording for the specified channel. Audio must be set to ON to hear live audio. On the local unit, audio can be heard live and in playback. Only audio for the selected camera will be heard. On the remote access software audio can only be heard in live mode.
SCHEDULE	Set the recording schedule. This menu item takes you to the Schedule Setup screen (see Figure 3-6).

Motion Zones

When you select **Partial Zone** in the **Motion Zone** menu, you can set up motion sensing zones (see **Figure 3-5**).

To move around each rectangular zone, use the arrow controls. Press **SEL** on each rectangular zone you want to include as part of the motion sensing zone. As you select each zone, the color changes. Press **ESC** to return to the **Record Menu**.

Figure 3-5 Motion Zone Setup Screen



Note Only selected zones will trigger motion recording.

Recording Schedules

To set up a recording schedule, select **SCHEDULE** in the **RECORD** menu. Use the arrow buttons to navigate through the items and set the recording schedule.

Figure 3-6 Recording Schedule Setup Screen



You can schedule recording in one hour increments from **0** to **24** (0:00 to 24:00). You can select individual blocks of time, blocks of time for all channels, entire channels, or the entire schedule. Motion recording, sensor recording and continuous recording can be used exclusively for the schedule, or mixed as needed. See *Table 3-5* for four ways to set the schedule.

To set up a recording schedule, select **SCHEDULE** in the record menu. Use the arrow buttons to select one of the items in *Table 3-5*. Then press **SEL** to toggle and select the recording method required (C = Continuous, M = Motion, S = Sensor, - = No recording).

Table 3-5 Schedule Recording Setup Fields

Field	Description
ALL	Selected recording mode is applied to the entire time zone and all channels (cameras 1 to 4).
CH1 to CH4	Selected recording mode is applied to the entire time zone for the specified channel.
Vertical Bar	Selected recording mode is applied to the entire channel for the selected time zone. Each vertical bar corresponds to one hour.
- Individual Block of Time	Selected recording mode is applied to the selected 1-hour increment for the selected channel.

Setting System Parameters

Use the **System Setup** screen to input system parameters.

Use the **UP** and **DOWN** arrow controls to navigate through the menu items and use the **LEFT** and **RIGHT** arrow controls to change the value of the menu items.

Figure 3-7 System Setup Screen



Follow [Table 3-6](#) to set global System parameters.

Table 3-6 System Setup Fields

Field	Description
DVR ID	Set the name of the DVR (see Figure 3-8). Press SEL , use the LEFT and RIGHT arrow controls to navigate through the position for each alphanumeric character. Use the UP and DOWN arrow controls to change the selected character. Press SEL to confirm the name.
DESCRIPTION	Press SEL to view system information (System version, storage capacity, IP address and MAC address. See Figure 3-9).
LOAD SETUP DEFAULT	Select ON to reset the system to the factory default settings.
ADMIN PASSWORD	Set the administrator password. After selecting this menu item you will be prompted for your current password and then the new password. Follow the prompts to change and confirm the new password. The default password is 1111 . Use the arrow controls to change the password: UP = 1 RIGHT = 2 DOWN = 3 LEFT = 4
NETWORK PASSWORD	Set the remote access password. You will need to enter this password when connecting to this DVR through the RAS program (see page 44). After selecting this menu item you will be prompted for your current password (the default password is 1111) and then the new password. Follow the prompts to change and confirm the new password. Use the arrow controls to change the password as described in ADMIN PASSWORD above.
DATE FORMAT	Set the desired date and time display format. Options are: YYYY/MM/DD YYYY-MM-DD MM/DD/YYYY MM-DD-YYYY DD/MM/YYYY DD-MM-YYYY

Table 3-6 System Setup Fields (Cont'd)

Field	Description
SET DATE & TIME	Set the present date and time for the DVR (see <i>Figure 3-10</i>). Press SEL , then use the LEFT and RIGHT arrow controls to navigate through the position of each alphanumeric character in the date and time. Use the UP and DOWN arrow controls to change the selected character. Press SEL to confirm the new date and time.
PTZ CONTROL	Set the PTZ camera speed, number, type, and ID (see <i>Controlling a PTZ Camera</i> , page 20).
LANGUAGE	Set the desired language.
REMOTE CONTROLLER ID	Set from 0–9 . Used with the unit optional remote control. If several units are in the same room, set each unit for a different ID. Use the remote control to select one by pressing the corresponding single digit code. The factory default is set to 0 . If only one unit is in the room, leave this set to the factory default of 0 . When set to 0 , the unit does not look for a select number (1–9) from the remote control. The on-screen remote control icon will always be on and the user can press any remote control key as required.

Figure 3-8 DVR ID Setup Screen



Figure 3-9 DVR Description Display Screen



Figure 3-10 Date and Time Setup Screen



Controlling a PTZ Camera

To control the PTZ functions of the camera, connect the controller to the RS485 port on the rear panel (see [Figure 2-2](#)).

Note For speed dome cameras that support RS485, connect them directly to the RS485 port.
If the camera is controlled with RS232C, use an RS485 to RS232C signal converter.

On the **PTZ Control Setup** screen (see [Figure 3-11](#)) you can select or set the protocol type of the camera that is the same as the one installed on the site. If the camera has a specific camera ID, select the camera ID using the **LEFT** and **RIGHT** arrow controls. The following options are available on the **PTZ CONTROL** screen:

- **CAMERA SPEED (19200, 14400, 9600, 4800, 2400)**
- **CAMERA NUMBER** (channel number that the PTZ is connected to)
- **CAMERA TYPE** (protocol type)
- **CAMERA ID (0–63)**

Figure 3-11 PTZ Control Setup Screen



Table 3-7 Compatible PTZ Protocols

SAMSUNG MPT-230	SONY EVI-D30	DYNACOLOR DSCP
WON WOO	DONGYANG DSC-230S	DONGYANG DSC-230M
DONGYANG DPC-100	DONGYANG DSC-240	DONGYANG DRX-500
DONGYANG DRX-502A	PELCO D-PROTOCOL	PELCO P-PROTOCOL
PELCO CM6700	COSTAR 2500	VICON V2311RB3
VICON VPS1300	VICON 422R	CNB PTZ 102N
KALATEL KTD-312	SENSOMATIC PTZ	ELMO PTC-200
CANNON VC-C4	HITRON SCANDOMEII	WOOJU (DRX-502A)
SAMSUNG MRX-1000	KCC-PT400	VIDO B-01
LG LPT-A100L	TSC	PIH-302
DS-120	SCC-641	WV-CS850
VC-C50i	NIKO NK-97	NEWBORN DOME
SJ-100	DY-255	HRX-700
VCL	KD6i	BOSCH

Setting Network Parameters

Set up your network parameters (for remote connection through the Remote Access Software) on the **Network Setup** screen. See *Chapter 5*, *Chapter 6*, and *Chapter 7* for more information about RAS.

Figure 3-12 Network Setup Screen



Follow [Table 3-8](#) to set your system network parameters.

Table 3-8 Network Setup Fields

Field	Description
PORT	Press SEL to enter the port number.
REMOTE ACCESS	Enable/disable remote access (through RAS).
BANDWIDTH SAVING	Enable/disable key frame transmission only. This feature is useful when your network bandwidth is not enough for live video streaming.
NETWORK TYPE	Set the type of network connection. Options are: LAN, DHCP, ADSL Note Other parts of the Network Setup screen change depending on what network type you select (see Network Types , page 23).
DDNS	Enable/disable the DDNS server.
DDNS SERVER NAME	Enter or edit the DDNS server name. Note This option only appears if DDNS is enabled.
SEND E-MAIL	Sets up sending e-mail alarm reports. This menu item takes you to the Send E-mail setup screen. Enter the appropriate email address and server information to enable sending e-mail reports. See Setup Sending E-Mail Reports , page 24, for more information.

Ports

When you connect one or more DVRs to a network through an IP sharing device, each device must have a unique RTSP port number for remote access to each unit from outside the LAN (Local Area Network). Also, the IP sharing device must be configured for port forwarding so that each port, when accessed on the IP sharing device, will forward to the appropriate DVR.

Note This port number is listed next to the **PORT** menu option in the **Network Setup** screen. If you plan to access the DVR units only from within the same LAN, the RTSP port does not have to be changed.

Network Types

There are three network types available. Each type requires different settings.

LAN

To use the LAN option when connecting the DVR to a network, the following information is required. See your network administrator if you do not have this information.

IP The fixed IP address of the DVR unit

Gateway The IP address of the Gateway

Subnet Mask The Subnet Mask for the LAN

DNS Server IP The IP address for the DNS server

DHCP

Select **DHCP** to use the DHCP option when connecting the DVR to a network. An IP address is automatically assigned by the DHCP server, which automatically assigns IP addresses and other parameters to new devices. The assigned IP address and MAC address are displayed when **DHCP** is selected.

If the network connection does not allow additional IP addresses, then an IP sharing device will be needed. In this case, forwarding may be needed to allow for a network connection. For more information on port forwarding, see the documentation for your IP sharing device, or contact your network administrator.

ADSL

To use the ADSL option when connecting the DVR to a network, the following information is required. See your network administrator if you do not have this information.

ID The user ID for the ADSL connection

Password The password for the ADSL connection

Your ADSL connection must have an RJ45 output to connect to the DVR.

When sharing the connection with other devices, an IP sharing device should be used. In this case, select **LAN** as the **NETWORK TYPE**. You must also configure the IP sharing device for port forwarding to allow for a network connection.

For more information on port forwarding, see the documentation for your IP sharing device, or contact your network administrator.

Setup Sending E-Mail Reports

To set your options for sending e-mail alerts, use the **UP** and **DOWN** controls to navigate through the menu items. Change the value of the menu item using the **LEFT** and **RIGHT** controls or by pressing **SEL** to manually change the entry.

Figure 3-13 Send E-mail Setup Screen



Table 3-10 describes the Sending E-mail options.

Table 3-9 Send E-mail Fields

Field	Description
IP NOTIFICATION	When enabled (set to ON), the DVR sends network information (IP address, Gateway, Subnet mask) to the specified e-mail address when the network information changes or when the system is rebooted.
EVENT ALARM	When enabled (set to ON), the DVR sends a captured image (JPEG), site (channel) name, and record type of the alarm that occurred to the specified e-mail address when the record type is set to either Motion or Sensor and the alarm is currently ON .
MAIL ADDRESS	Press SEL to enter the e-mail address that the DVR will send the e-mail to. For example: <i>bob.smith@honeywell.com</i>
MAIL SERVER NAME	Press SEL to enter the mail server name that the DVR will be sending e-mails to.
ID	Press SEL to enter your e-mail account ID/user name.
PASSWORD	Press SEL to enter your e-mail account password.
RETURN MAIL ADDRESS	Press SEL to enter the e-mail address for returning e-mails due to delivery failure or delay.

Note We recommend that users do not use their web-mail address (such as Hotmail or Yahoo) as the e-mail accounts that the HRDE4X4 sends e-mails to. Use your company e-mail system instead.

Storage Setup

To assign how your DVR reacts when the hard drive is full, set the storage parameters in the **Storage Setup** screen.

Figure 3-14 Storage Setup Screen



Table 3-10 describes the Storage field options.

Table 3-10 Storage Setup Fields

Field	Description
OVERWRITE	When enabled, the DVR will continue recording and overwrite the oldest existing recorded data once the hard drive is full. When disabled, recording will stop once the hard drive is full.
FORMAT	Format the hard drive. Use the LEFT and RIGHT arrow buttons to select ON , then press SEL . You then have the option to CANCEL or CONFIRM . Caution All recorded data will be lost. We recommend that you archive any data that you may need in the future before you format the hard drive.

Saving Setup

To preserve the setup values that you have selected, open the **SAVE SETUP** screen, and then select **CONFIRM** and press **SEL**.

Figure 3-15 Save Setup Screen



This completes your DVR setup. Proceed to *Chapter 4, Front Panel Operation* for information on live viewing, searching for video, and archiving.

4

Front Panel Operation

This chapter covers:

- Live viewing
- Searching
- Playing back
- Live networked remote monitoring
- Archiving video to a USB stick

Note This chapter assumes you have already correctly installed and configured your DVR. If you have not, see *Chapter 2* for Installation and *Chapter 3* for Configuration.

Live Viewing Window

In the Live window, video inputs from the cameras are displayed as they are configured in the **Live Setup** screen (see *Live Mode* on page 14). *Figure 4-1* shows the layout of the live viewing window. Various on-screen display (OSD) symbols, which indicate the status of the DVR, are described in *Table 4-1*.

Figure 4-1 Live Viewing Window



Table 4-1 Status Indicator Icons in the Live Viewing Window













Key	Description
	Continuous recording in progress.
	Manual recording in progress (overrides other modes).
	Sensor alarm recording in progress.
	Motion alarm recording in progress.
	Alarm indicator. When there is an alarm (sensor or motion alarm) in the video channel, this icon will be highlighted bright red.
	Indicates that alarm output is activated.
	Indicates that a RAS user is connected to the DVR.
	Indicates that the sequencing mode is enabled.
	Indicates storage is set to overwrite the oldest recorded data.
	Indicates a remote control is selected for use with the unit.

Table 4-2 Button Functions in Live Viewing Window

Button	Description
SETUP	Launch the SETUP menu.
SEQ	Enable/disable the automatic sequential display of channels in full screen or automatic sequencing of the highlighted channel in quad display mode. Audio is heard from the highlighted channel in quad display mode when audio is enabled.
SEARCH	Launch the SEARCH window (see <i>Figure 4-2</i>).
	Select the channel to be displayed in full screen mode.
	Switch between full and quad screen display modes.
ESC	No action taken.
RECORD	Perform continuous or manual recording for all channels.

Search Window

Press **SEARCH** in live mode to enter the Search window. The screen will appear as in *Figure 4-2*.

Figure 4-2 Search Menu



Event Search

The **EVENT SEARCH** window (see *Figure 4-3*) is used to find stored video. Three categories of search filters can be applied: **DATE**, **CHANNEL** and **TYPE**. Press **SEL** to select a value and move down to the next category and use the **UP** arrow button to move up to the categories you have previously entered. The **ESC** button will return the user to the previous screen.

Searching for an event:

1. Select the date of the video to begin searching. Use the **LEFT**, **RIGHT**, **UP** and **DOWN** buttons to navigate through the days.
2. Once you have selected the date, press **SEL** to move to the **CHANNEL** selector.
3. Use the **LEFT** and **RIGHT** buttons to change the channel selection from **ALL** to any of the four available channels.
4. Once you have selected the channel, press **SEL** to move to the **TYPE** selector.
5. Use the **LEFT** and **RIGHT** buttons to change the type of recording to **ALL**, **MOTION**, **SENSOR**, **MANUAL**, or **CONTINUOUS**.
6. Once you have selected the type of recording to search for, press **SEL** to produce a list of instances that fit your search criteria.

Figure 4-3 Event Search Screen



Figure 4-4 Event Search List Screen



7. Use the **UP** and **DOWN** buttons to scroll through the on-screen listings.
8. Use the **LEFT** and **RIGHT** buttons to display a list of events that happened previous to or after the current selection.
9. Once the desired event has been selected, press **SEL** to start playing back the selected video.
10. Press **ARCH** to launch the archiving function in playback mode (see *Archiving Video* on page 36 for more information).

Time-Line Search

The **TIME-LINE SEARCH** window (see *Figure 4-5*) is used to find the stored video by using the time line bar.

Figure 4-5 Time-line Search Date Select Screen



1. Select the date of the video to begin searching by using the **LEFT**, **RIGHT**, **UP**, and **DOWN** buttons to navigate through the days.
2. Once you have selected the date, press **SEL** to move to the time line search window (see *Figure 4-6*).
3. Use the **LEFT** or **RIGHT** buttons to select a time zone on the 24 hours time table. Once you have selected the time zone, press the **DOWN** or **SEL** buttons to move to the 60 minutes time table.

Figure 4-6 Time-line Search Screen

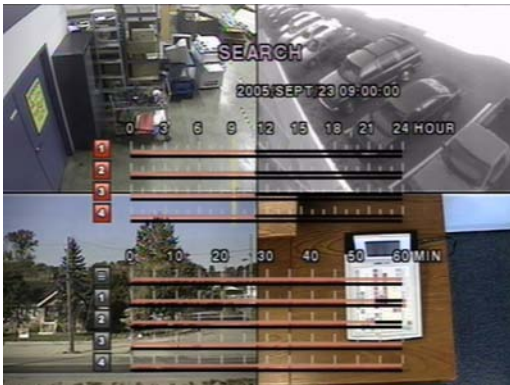

4. Select All or a specific channel to search by using the **UP** and **DOWN** arrow buttons. Notice that the highlighted icon on the lower left side of the screen changes when **UP** or **DOWN** is pressed.
5. Once you select the channel, use the **LEFT** and **RIGHT** arrow buttons to move the time line select **Bar** (yellow) to the point on the 60 minute time table that you wish to start playing the video clip (time zones with recorded video are indicated by a red underline).
6. Press **SEL** to playback the recorded video.
7. Press **ARCH** to launch the archiving function in playback mode (see *Archiving Video* on page 36 for more information).

Go To Search

You can search for video data from a specific instance by setting the date and time in the **GO TO** search window (see *Figure 4-7*). Use the **LEFT** or **RIGHT** arrow buttons to move through the date and time values in this menu. Use the **UP** and **DOWN** arrows buttons to change the date and time values. Press **SEL** when the appropriate date and time is entered to playback the recorded video.

Figure 4-7 Go To Search Screen



Go First Search

You can access the oldest recorded data on the DVR hard drive by selecting **GO FIRST** on the **SEARCH** window.

Go Last Search

You can access the latest recorded data on the DVR hard drive by selecting **GO LAST** on the **SEARCH** window.

Log List Search

You can access the **LOG LIST** search screen (see *Figure 4-8*) by selecting **LOG LIST** on the **SEARCH** window. Select a date and press **SEL** to open the **LOG LIST** from that date (see *Figure 4-9*).

Figure 4-8 Log List Search Screen



Figure 4-9 Log List Screen



Archive Search

The **ARCHIVE SEARCH** window (see *Figure 4-10*) is used to find previously stored video or images.

Figure 4-10 Archive Search Screen



1. Select the date to begin searching by using the **LEFT**, **RIGHT**, **UP**, and **DOWN** buttons to navigate through the days.
2. Once you have selected the date, press **SEL** to open the list of stored data (see *Figure 4-11*).

Figure 4-11 Archive List Screen



3. Use the **UP** and **DOWN** buttons to scroll through the on-screen listings.
4. Use the **LEFT** and **RIGHT** buttons to display a list of stored events that happened previous to or after the current selection.
5. Once the desired event has been selected, press **SEL** to view the still image or the first frame of the selected video.
6. Press **ARCH** to launch the archiving function in playback mode (see *Archiving Video* on page 36 for more information).

Play Mode

During playback of a recorded event, the mode changes from **SEARCH** to **PLAY**. While in **PLAY** mode, you may return to the previous **SEARCH** screen by pressing **ESC**. Playback starts in quad mode with channel 1 highlighted by default. If audio is enabled, it will only play from the highlighted channel.

Figure 4-12 Play Mode Screen



Table 4-3 Button Functions in Play Mode

Button	Description
ESC	Return to the previous menu screen, search list, or exit the menu.
◀◀ REW	Press to rewind the footage at 1x, 2x, 4x, 8x, and 16x speeds. Reverse playback speed is shown as ◀ (normal), 2◀◀ (2 times normal), 4◀◀ (4 times normal), 8◀◀ (8 times normal), and 16◀◀ (16 times normal) at the bottom right of the screen.
●●◀ F/REV	Jump/Step backward. The playback position moves one minute backward.
▶/ PLAY/PAUSE	Press to play or pause recorded video.
F/ADJ ▶●●	Jump/Step forward. The playback position moves one minute forward.
FF ▶▶	Press to fast forward the footage at 1x, 2x, 4x, 8x, and 16x speeds. Playback speed is indicated as ▶ (normal), 2▶▶ (2 times normal), 4▶▶ (4 times normal), 8▶▶ (8 times normal), and 16▶▶ (16 times normal) at the bottom right of the screen.
	View channel 1 in full screen.
	View channel 2 in full screen.
	View channel 3 in full screen.
	View channel 4 in full screen.

Table 4-3 Button Functions in Play Mode (Cont'd)

Button	Description
	Switch the live view between quad and full screen mode displaying the highlighted channel.
ARCH	Press to launch the archiving function.

Network Mode

The DVR provides a live remote monitoring feature. Remote monitoring requires installation of a Remote Access Software program on your PC (see *Chapter 5, RAS Installation*). A LAN connection using the RJ45 connector on the DVR rear panel is mandatory for remote connection. For detailed features on operation of the RAS program, please refer to *Chapter 6* and *Chapter 7*.

For local operation purposes, the frame rate is limited to 1 frame/sec when there is no recording operating on the DVR. When recording is in progress, the video frame rate for live monitoring will follow the recording frame rate.

Figure 4-13 Main GUI Screen of RAS Program

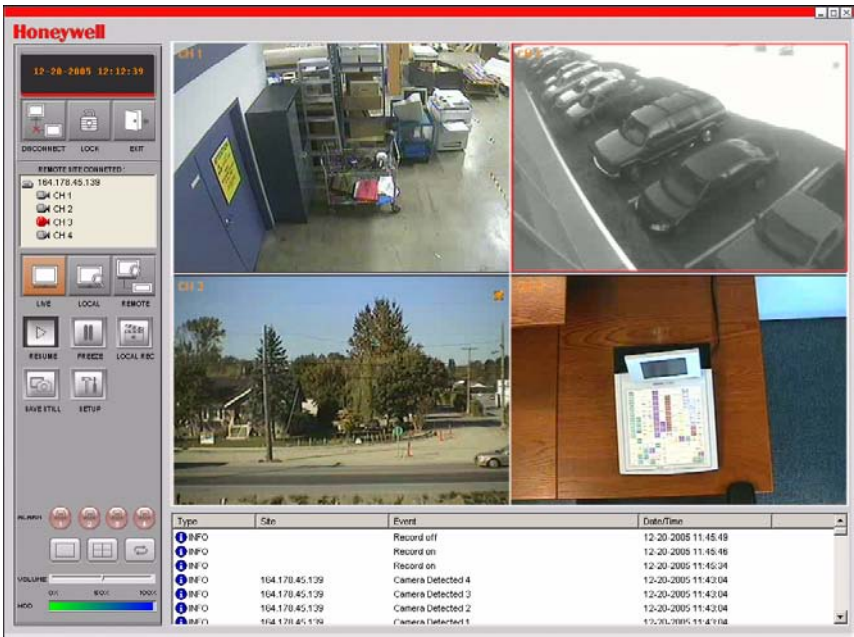

Archiving Video

To archive a still image or video clip to a USB stick, the user must first find and archive a still image or video clip.

Archiving Still Images onto USB

Still images can be captured and archived onto the hard drive in live mode or while playing back recorded video. In live mode, press **ARCH** to capture and store the still image. The still image will be archived onto the hard drive for later retrieval and can be transferred to a USB stick immediately if you have one available.

When you press **ARCH**, you will see the Still Image Archive Success message. Once this is displayed the HRDE4X4 will ask if you want to Save to USB. To save to a USB memory stick, connect the DVR to a USB stick through the USB port on the front panel. Select **Yes** and press **SEL** to start the archiving process.

Archiving Video onto USB

While in playback mode, press **ARCH** to launch the archiving function. The DVR will ask whether to store a **Still Image** or **Video** clip (see *Figure 4-14*). If the user selects **STILL**, it will store the captured still image on the HDD (see *Archiving Still Images onto USB*, page 36). If the user selects **VIDEO**, the DVR ask for the length of the video clip to archive and will keep a record of the archiving operation without actually writing to the hard drive. You may now save the video clip to a USB memory stick, or choose to save it later.

Note Make sure to transfer the data to the USB stick before the actual video content is erased from the hard drive, otherwise the clip will be lost, even if archived to the hard drive.

Figure 4-14 Archive Mode Screen



Once you have entered a length of time and video clip is stored, you will receive the Video OK message and then will be asked if you want to save the clip to a USB stick (Save to USB?). To save to a USB memory stick, connect the DVR to a USB stick through the USB port on the front panel. Select **Yes** and press **SEL** to start converting the corresponding portion of video into an AVI file and store it onto the USB stick.

Note When archiving video from a Quad view to the USB stick, only the video from the one highlighted camera will be moved to the USB stick.

Transferring Still Images or Video onto USB

To begin transferring stored images or video to a USB stick, connect the DVR to a USB stick through the USB port on the front panel (see [Figure 3-1](#)). Press **Search** then select **Archive**, this will bring up the **ARCHIVE** screen (see [Figure 4-15](#)), which will allow you to select a date to search for stored images or video.

Figure 4-15 Archive Menu Screen



Press **SEL** to retrieve a list of archived images or video (see [Figure 4-16](#)).

Figure 4-16 List of Archived Files



Select one of the files in the archived list using the **UP** and **DOWN** arrow buttons, and then press **ARCH** to transfer the file to the USB stick. If there is enough space for archiving, the DVR will start transferring the file. In the case of video, the DVR will convert the video and audio into an AVI format while transferring the video file into the USB stick. This will allow the video to be played back using programs such as the Windows Media Player™. See [Appendix B, Playing AVI Archive Clips](#) if your archived clips are not playing back on your local PC for procedures to install updated video codecs to assist with this.

Note When archiving video from a Quad view to the USB stick, only the video from the one highlighted camera will be moved to the USB stick.

RAS Installation

Minimum PC Requirements

Before installing the Remote Access Software program, check your PC specifications. The DVR remote software may not perform correctly if the PC does not meet these minimum requirements:

Table 5-1 Recommended and Minimum PC Requirements

PC Specification	Minimum Requirement	Recommended
CPU	Intel Pentium III 500 Mhz	Intel Pentium IV 2 Ghz
Memory	128 MB	256 MB
VGA	16 MB	64 MB
Resolution	1024 x 768	1024 x 768
Disk Space	10 MB	10 MB
Operating System	Windows 2000 Professional SP4	Windows 2000 Professional SP4, XP Professional SP2, and XP Home
Network	10/100Base T	10/100Base T
Direct X	Direct X 8.1	Direct X 8.1 or higher

Installing the RAS Program

1. Insert the Remote Viewer software CD provided with the HRDE4X4 DVR into the CD-ROM drive of your PC.
2. Double-click the RAS setup file or icon () to start the installation process.
3. The RAS splash screen appears while the installation wizard loads.
4. Click **Next** to use the default destination location (see *Figure 5-1*), or click **Browse...** to manually select a different destination location.

Figure 5-1 Choose Destination Location



5. Select the **Typical** Setup. Click **Next**.

Figure 5-2 Choose the Setup Type

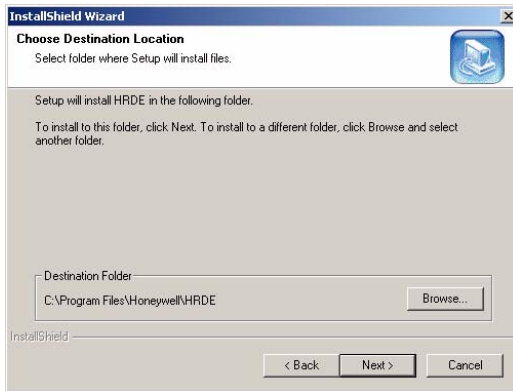
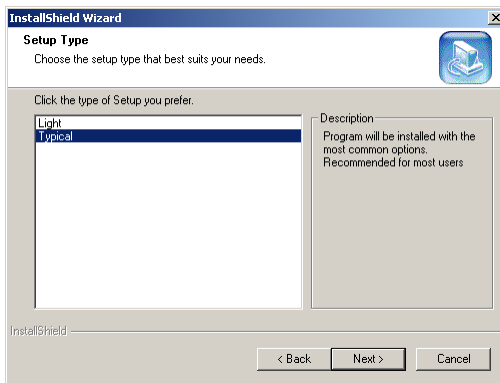

6. Choose a language for the installation and click **Next**.

Figure 5-3 Choose Language

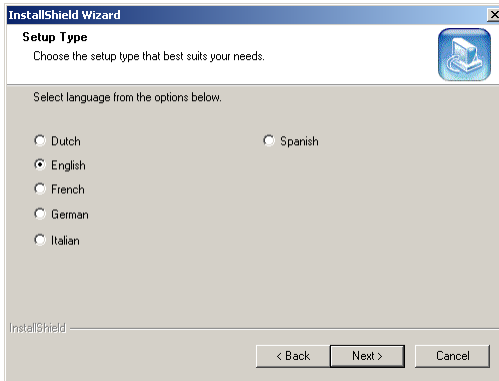

7. Click **Next** to use the default program folder (see *Figure 5-4*), or manually select a folder from the list of **Existing Folders**.

Figure 5-4 Choose Program Folder



8. Wait a few minutes while the setup completes.
9. Double-click the **RAS** icon (see *Figure 5-5*) that should now be on your desktop to launch the program.

Figure 5-5 RAS Icon



6

RAS Operation

When the installation is complete, double-click the RAS icon (see *Figure 5-5*) on your desktop to launch the program.

Live Viewing

Live Viewing Interface

Figure 6-1 RAS Live Viewing Interface (Connected)

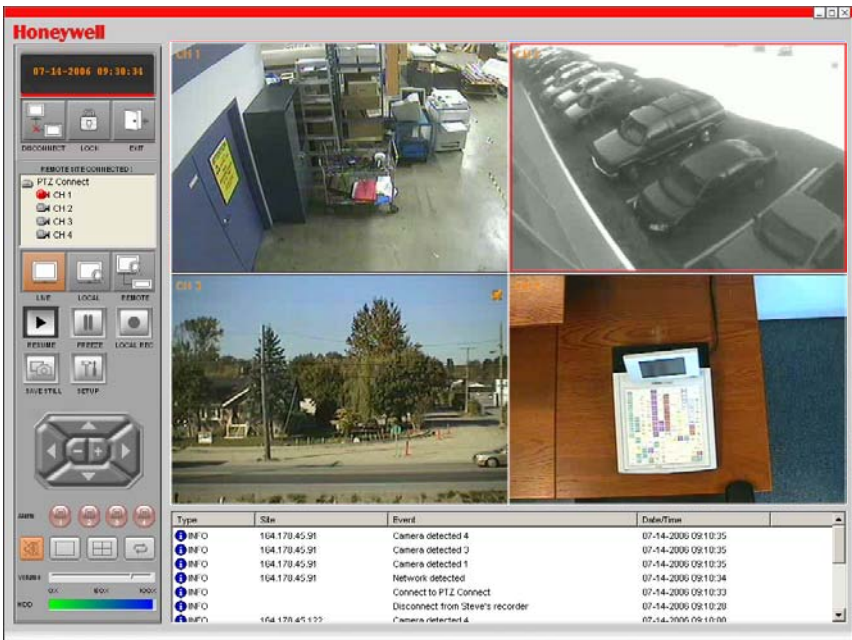

Table 6-1 Live Viewing Interface Controls







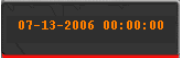

Interface Control	Description
	<p>Displays the current date and time when viewing live video.</p>
	<p>Click to Connect to the DVR.</p> 
<p>If you click Connect, this Connect pop up window appears. Enter the IP Address and the Port number. Then select the Protocol type and enter the network Password. Click OK to initiate the connection.</p>	<p>Caution Port No: It should be the same as the DVR's port number (the default port number is 5445 on both DVR and RAS).</p>
<p>Caution Password: It should be the same as the DVR's network password (the default password is 1111), set in the System menu on your DVR.</p>	<p>Remote access should be set to ON in the Network Setup menu on the DVR.</p>
<p>Note Maximum of 512 connection entries.</p>	<p>Click to Disconnect from the DVR.</p>
	<p>Note This button only appears when you are remotely connected to a DVR.</p>
	<p>Click to open the Local Search user interface. See Search and Playback Viewing, page 46, for information on searching the hard drive of the local PC for recorded video.</p>
	<p>Click to open the Remote Search user interface. See Search and Playback Viewing, page 46, for information on searching the hard drive of the remotely connected DVR for recorded video.</p>
	<p>Click to open the Live Video user interface.</p>
	<p>Click to Lock all the operations on the DVR.</p> <p>Note When this button is clicked it changes to the Unlock button.</p>

Table 6-1 Live Viewing Interface Controls (Cont'd)

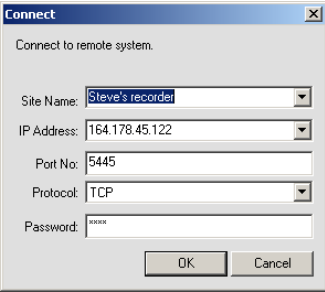









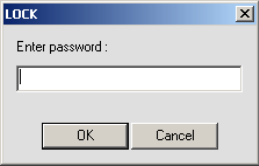





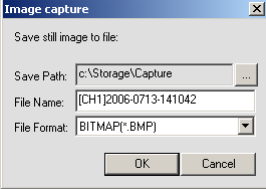



Interface Control	Description
 UNLOCK	<p>Click to Unlock all the operations on the DVR.</p> <p>Note When this button is clicked it changes to the Lock button.</p>
	<p>When you click the Lock or Unlock button, the password entry window appears. When you Lock the operations on the DVR, you need to set and enter the Password. When you Unlock the operations on the DVR, you need to enter the Password previously set while locking. The factory default password is the enter key on your PC. Press Enter.</p>
	<p>This Remote Site information panel shows the DVR site RAS is currently connected to, and the corresponding channel information.</p>
 RESUME	<p>Click to Resume live video updates.</p>
 FREEZE	<p>Click to Freeze live video updates.</p>
	<p>Enable or disable the recording of live video for future playback by the RAS Viewer program. The video is saved to c://Storage/ on the local PC disk, specified in RAS Setup, Capture. This option allows saving and playback of all cameras at the same time.</p>
 SAVE STILL	<p>Click to Save a Still image. Only the selected red outlined camera will be saved.</p>
	<p>When you click the Save Still button, this window appears, offering you image capturing options. The still image can be captured in either jpeg or bmp file format. The image will be saved in the folder selected on the General Setup screen (see <i>General Setup</i> on page 57) unless you specify otherwise. You can also change the default File Name for the still image.</p>
 SETUP	<p>Click to Setup the configuration of the RAS program.</p>
 EXIT	<p>Click to Exit from the operations of the RAS program.</p>
	<p>These Alarm indicators illuminate when a sensor input is active on the corresponding channel on the remote HRDE4X4.</p>
	<p>Click to toggle the audio sound on and off.</p>
	<p>Click to view the red outlined video channel in Full Screen view.</p>

Table 6-1 Live Viewing Interface Controls (Cont'd)

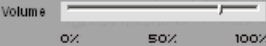
Interface Control	Description
	Click to view all the channels in a Quad Screen view.
	Click to start or stop the Sequential display of each channel in full screen mode.
	Adjust audio Volume using this slide bar.
	This green bar indicates the remaining hard drive storage capacity.
	This log lists client activity information.
	Click these buttons to Minimize , Maximize or Close the RAS window.

Search and Playback Viewing

You can access the Search window by clicking either **Local Search** () to search the local PC hard drive or **Remote Search** () to search the remotely connected DVR.

Search and Playback Interface

Figure 6-2 Search and Playback Interface

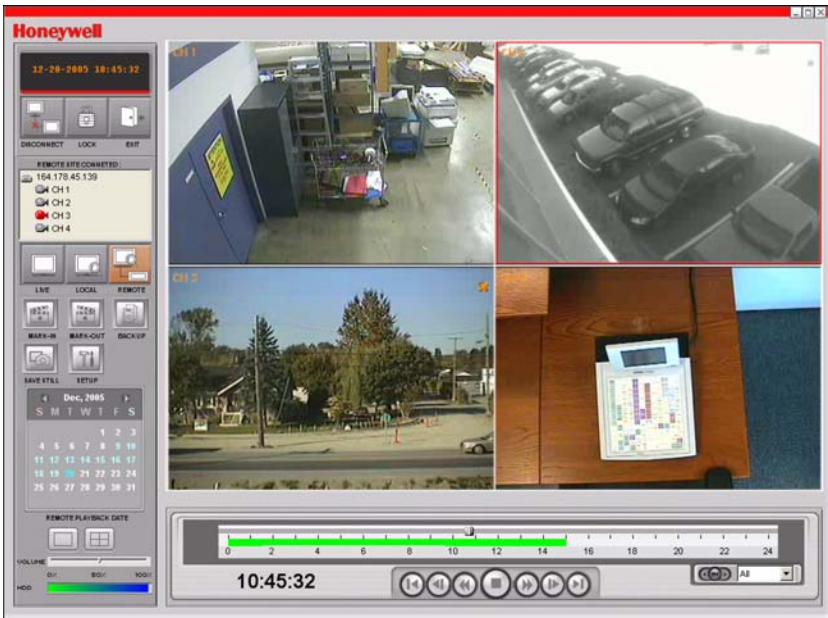

Table 6-2 Search and Playback Interface Controls











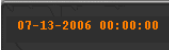





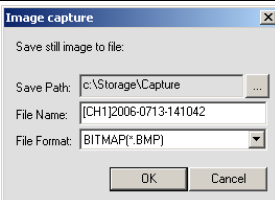



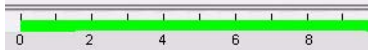



Interface Control	Description
	<p>Displays the recorded date and time of the video being played back.</p>
	<p>Click to open the Local Search user interface, to search the hard drive of the local PC for recorded video.</p>
	<p>Click to open the Remote Search user interface, to search the hard drive of the remotely connected DVR for recorded video.</p>
	<p>Click to open the Live Video user interface.</p>
	<p>Click to Exit from the operations of the RAS program.</p>
	<p>Click to Backup recorded video from the remote HRDE4X4 to the PC in AVI format. AVI format can be played back using Windows Media Player. Only one camera at a time can be saved and played back. The AVI format video will be saved in the RAS setup backup folder</p>
	<p>Click to Save a Still image in either BMP or JPG format.</p>
	<p>When you click the Save Still button, this window appears, offering you image capturing options. The still image can be captured in either jpeg or bmp file format. The image will be saved in the folder selected on the General Setup screen (see General Setup on page 51) unless you specify otherwise. You can also change the default File Name for the still image.</p>
	<p>Click this button (Mark In) to set the start time for backing up recorded video in AVI format to the local PC.</p>
	<p>Click this button (Mark Out) to set the end time for backing up recorded video in AVI format to the local PC.</p>
	<p>The Calendar shows dates with recorded video in light blue and the currently selected date in dark blue.</p>

Table 6-2 Search and Playback Interface Controls (Cont'd)

Interface Control	Description
	<p>The timeline shows recorded data in dark green on the bar. You can adjust the time line scale and move it to the time you wish to start playing back. Click Play to display the recorded video.</p>
	<p>Click to Play the recorded video clip.</p>
	<p>Click to Stop or pause the displayed video clip.</p>
	<p>Click to toggle the Fast Forward speed video is being played back at (choices are 2, 4, 8, 16).</p>
	<p>Click to toggle the Fast Reverse speed video is being played back at (choices are 2, 4, 8, 16).</p>
	<p>Click to Reverse One Frame in the video clip being played back.</p>
	<p>Click to Advance One Frame in the video clip being played back.</p>
	<p>Click to jump back one minute in the video clip.</p>
	<p>Click to jump forward one minute in the video clip.</p>
<p>11:15:53</p>	<p>Displays the recording time of the video being played back.</p>
	<p>Select a channel (Camera 1–4) to search for recorded video.</p>
	<p>Click the left or right arrow buttons to advance or reverse the time slide bar by one hour. Click the middle button to switch the time slide bar between a 24 hour or one hour time period.</p>
	<p>Click to view the highlighted channel in Full Screen view.</p>
	<p>Click to view all the channels in a Quad Screen view.</p>

Back Up a Video Clip in AVI Format

You can backup the recorded video clips in AVI format on the Search User Interface.

1. Search for and play back video, locate which camera and the time where you want to start backing up video from. Select a camera to back up video from by clicking on the camera image. The selected camera image will now have a red line surrounding it.
2. Set the starting point of the video clip to be backed up on the green timeline by using the slide bar and clicking the **Mark In** button ().

- Then set the ending point on the green timeline by using the slide bar and clicking the **Mark Out** button () to set the ending point of the video clip to be backed up.

Figure 6-3 Main User Interface with Back Up Times Marked



Move the slide bar to the start of the clip to back up and click **Mark In**.

The dark green bar indicates the portion of recorded video that will be backed up.

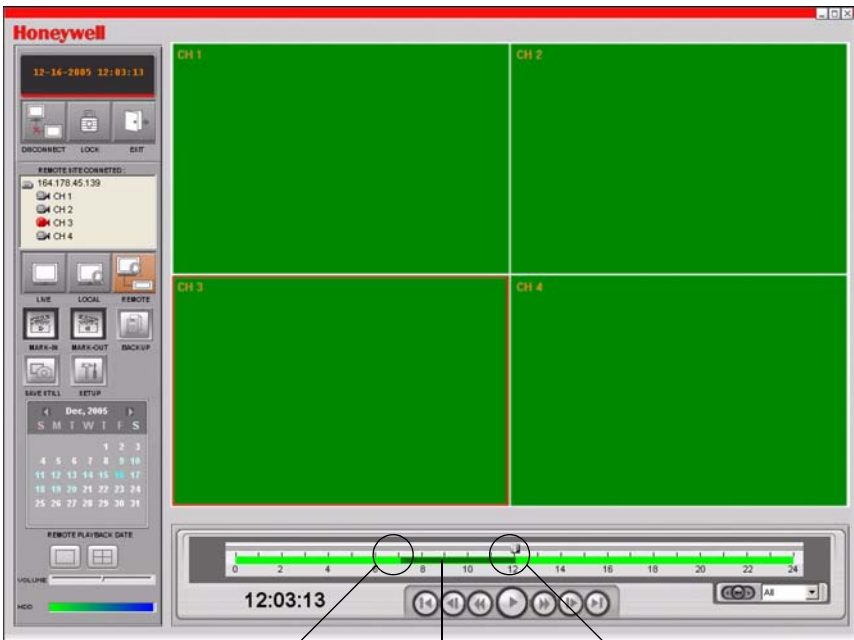
Move the slide bar to the end of the clip to back up and click **Mark Out**.

- Click **Backup** (). *Figure 6-4* appears as below.

Figure 6-4 AVI Backup Window

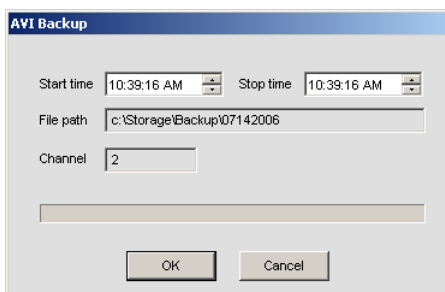

5. You can adjust the **Start** and **Stop** times for the video clip in the AVI Backup window.
6. Click **OK** to start the backup process.
7. Video is saved with a folder name of the date of the recorded video and a filename of the camera and start time of the downloaded video.

Figure 6-5 Windows Explorer with Video Clips Selected



Example The folder is 02172006 for a recorded date of February 17, 2006. The filename is [CH1]08_30_08 for Camera 1 and a video start time of 8:30:08 AM. The filename with the AVI extension contains the video and the filename with the SMI extension contains the date and time overlay to be played back on top of the video. For a time and date overlay you will need the FFDSHOW codec installed on your PC. In the FFDSHOW Video Decoder Configuration enable the subtitles option (see [Appendix B, Playing AVI Archive Clips](#)).

The clip will be automatically saved to the file location specified in [General Setup](#), page 51. Navigate to the folder, find the AVI file you have archived and open it. This will allow the video to be played back using programs such as the Windows Media Player.

See [Appendix B, Playing AVI Archive Clips](#) if your archived clips are not playing back on your local PC.

RAS Configuration

Click **Setup** () to open the **Setup** menu for the RAS program.

General Setup

Click **Setup** to open *Figure 7-1*. Set the options as follows:

Figure 7-1 **General Setup Screen**

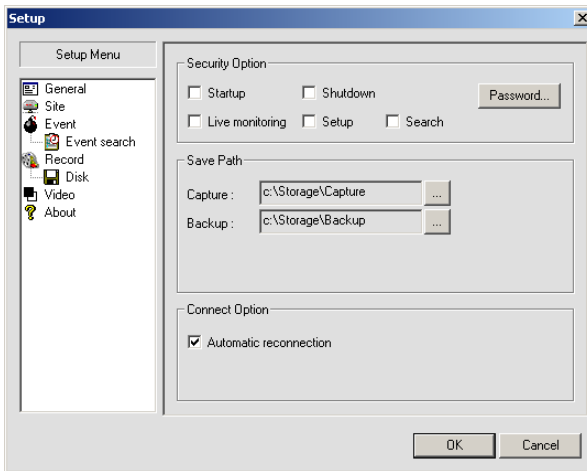

1. In the **Security Option** section, click the checkboxes to place a checkmark in those boxes. The options that you select will now require a password when a user accesses that function. The same password is used for all security options enabled.
2. Select a **Save Path** for saving **Capture** and **Backup** files to the hard drive. Click ... for the corresponding file type to manually select a destination folder.
Capture files are single image files (.bmp or .jpg) saved using the **Save Still Image** button.

Backup files are saved using the backup button in the search interface. Only one camera is viewable and files are saved in AVI format to be played back using Windows Media Player.

3. Click **Password...** to open the **Change Password** screen (see *Figure 7-2*).

Figure 7-2 Change Password Screen



A dialog box titled "Change Password" with a close button (X) in the top right corner. It contains three text input fields: "Old Password:" with a masked password "xxxx", "New Password:" with a masked password "xxxx", and "Confirm Password:" with a masked password "xxxx". At the bottom, there are two buttons: "OK" and "Cancel".

4. Enter the appropriate passwords in the **Old**, **New** and **Confirm** text boxes. The factory default password is no password, simply press the **Enter** key.
5. Click **OK** to save the new password.

Site Setup

Click **Site** on the left-hand panel of the **Setup** menu. The **Site** menu (see *Figure 7-3*) shows the information of all the DVR sites you have configured with RAS. You can Add, Remove or Modify sites on this menu. To Add a site:

1. Click **Addition**.

Figure 7-3 Site Menu

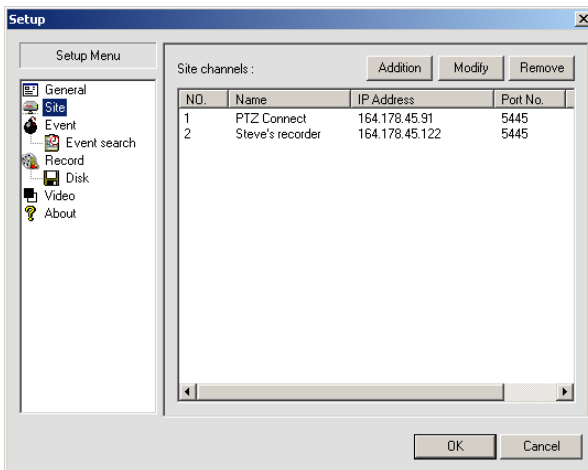

A dialog box titled "Setup" with a close button (X) in the top right corner. It has a "Setup Menu" tab selected. On the left is a tree view with "Site" selected. On the right, there is a "Site channels:" section with "Addition", "Modify", and "Remove" buttons. Below this is a table with the following data:

NO.	Name	IP Address	Port No.
1	PTZ Connect	164.178.45.91	5445
2	Steve's recorder	164.178.45.122	5445

At the bottom of the dialog are "OK" and "Cancel" buttons.

2. Enter the **Site Name**, **IP Address**, **Port No.**, **Protocol**, and **Password**, as necessary.
3. Click **OK**.

Note If necessary, double-click a channel **Name** to enter a new one.

Event Setup

Click **Event** on the left-hand panel of the **Setup** menu. In the **Event** menu (see *Figure 7-4*) you can set the event items that will be included in the event list and log, the amount of local disk space you want to allow, and the save path for the event log.

Figure 7-4 Event Menu

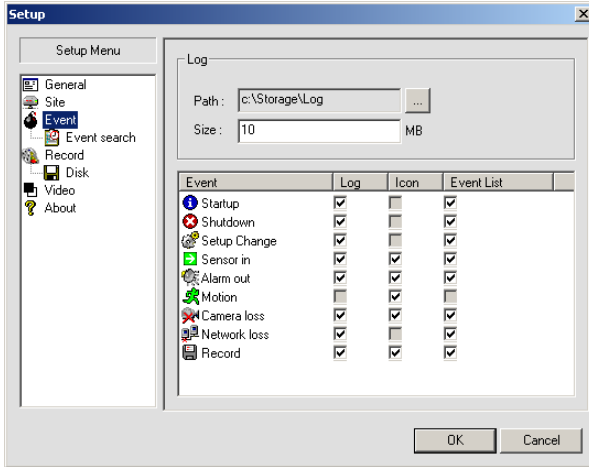

Event Search Setup

Figure 7-5 Event Search Menu

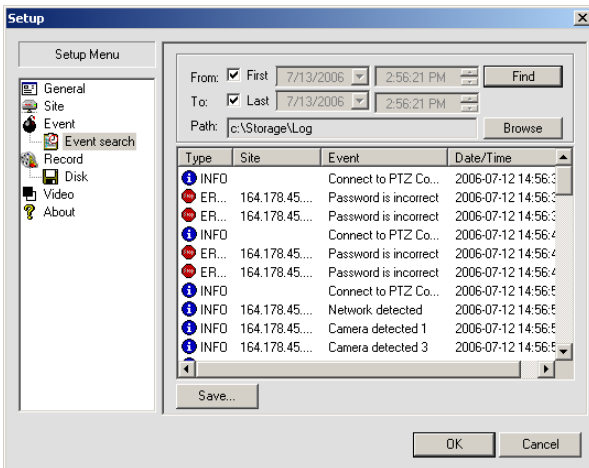

Click **Event Search** on the left-hand panel of the **Setup** menu. In the **Event Search** menu (see *Figure 7-5*) you can **Find** an event log for a time period specified in the **From** and **To**

fields. Click **Save** to save a text version of the log file to the folder specified in **Path**. Click **Browse** to change the **Path** folder used for saving the log file.

Record Menu

Click **Record** on the left-hand panel of the **Setup** menu. In the **Record** menu (see *Figure 7-6*) you can set the recording conditions for **Always**, **Event**, or **Auto** recording. You can also select to record individual channels or **All** the channels.

Note Live video will only be recorded to the local PC while the Viewer software is connected to the remote digital video recorder and in Live view mode. Video will be recorded based on the settings in the table below.

Figure 7-6 Record Menu

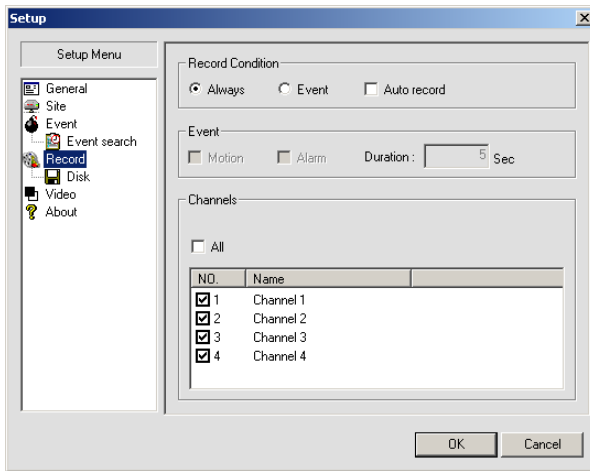

Table 7-1 Record Menu Settings

Setting	Operation
Autorecord	When a user connects remotely, the Local Rec button will automatically be enabled (RED) and video will be recorded to the local PC hard disk based on settings in this Record menu.
Always	When checked and the Local Rec button is enabled (RED) in live monitoring live video will be recorded to the local PC hard disk for channels enabled.
Event	When checked and the Local Rec button is enabled (RED), Live motion or alarm events will be recorded to the local PC hard disk.
Motion	Will record live motion events for the channels enabled, when checked.
Alarm	Will record live alarm events for the channels enabled, when checked.
Duration	Will record this duration of post-event video, when checked.
Channel	Will record enabled channels.

Disk Menu

Click **Disk** on the left-hand panel of the **Setup** menu. In the **Disk** menu (see *Figure 7-7*) you can select the local disk to use and the amount of **Disk Space** you want to allow the program to use for recording. You can also select the option to overwrite data or to stop recording when the maximum amount of disk space is full.

Figure 7-7 Disk Menu

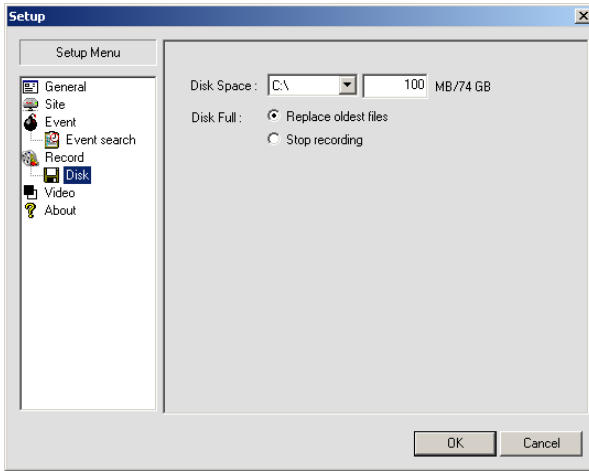

Video Menu

Click **Video** on the left-hand panel of the **Setup** menu. In the **Video** menu (see *Figure 7-8*) you can adjust the **Brightness**, **Contrast**, **Hue**, and **Saturation** of the live video or video being played back in the main user interface.

Figure 7-8 Video Menu

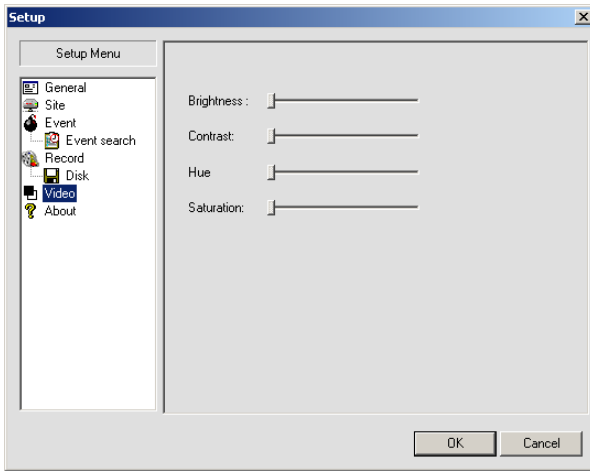

About Menu

Click **About** on the left-hand panel of the **Setup** menu. The **About** menu provides information on the RAS program.

A

DVR Firmware Upgrade

This appendix covers upgrading the firmware on your DVR unit. Check the Honeywell Video Systems website for firmware upgrades at <http://www.honeywellvideo.com>.

1. Copy Firmware Upgrade to USB Stick

In order to carry out the upgrade, the upgrade firmware must first be downloaded and copied onto the USB stick. Create a new folder in the USB stick and copy the upgrade firmware **app.bin** into the folder. The folder name must be **upgrade**.

After the upgrade firmware is copied into the USB stick, follow *2. Start Engineering Mode*, *3. Upgrading Using USB Stick* and *4. Verifying Software Installation* to complete the upgrade.

2. Start Engineering Mode

The DVR firmware can only be upgraded from the front panel of the unit using a USB memory stick. Firmware upgrades can be done in engineering mode (see *Figure A-1*). To start engineering mode:

1. Press **SETUP** and enter the **Setup** menu.
2. Go to the **SYSTEM** menu and select the **ADMIN PASSWORD** menu item.
3. Enter the password as **12341234**, and press **SEL**.

Note The space provided to enter the **Admin** password is only designed for four characters. Entering the last four characters will not appear on the screen, but they do serve to open the Engineering mode.

Figure A-1 Engineering Mode



3. Upgrading Using USB Stick

1. Connect the USB stick with the upgrade file saved on it to the USB port on the front panel (see *Figure 3-1*).
2. Select **USB Upgrade** and press **SEL**. The **UPGRADE** will start automatically.
3. After the upgrade is complete, press **SEL** to return to the **DVR Diagnostics** screen.
4. Select **Boot Application** and press **SEL** to reboot the DVR with the updated firmware.

4. Verifying Software Installation

1. Press **SETUP** and log on.
2. Select **SYSTEM** and press **SEL**.
3. Select **DESCRIPTION** and press **SEL**.
4. Check the version displayed. This should match to the new software version you have installed.

B

Playing AVI Archive Clips

It is recommended that you install the FFDSHOW codec included on the CD that came with your unit on your windows PC to properly review backed up or archived video. You can have a date and time overlay on your AVI video by installing the FFDSHOW codec as described below:

1. Insert the Honeywell RAS CD provided with the HRDE4X4 DVR into the CD drive on the PC you want to playback clips with.
2. Open the **Codecs** folder.
3. Double-click the file **ffdshow-xxx.exe** to run the codec installation program (where xxx is the file date).
4. Follow the installation wizard prompts to install the **FFDShow** program with the default settings.
5. Once FFDSHOW is installed, enable Text Overlay of time and date on your video by enabling Video decoder Subtitles as follows on your windows PC.
 - a. Open FFDSHOW (**Start** ► **All Programs** ► **FFDSHOW** ► **Video Decoder Configuration**).

Figure B-1 FFDSHOW Video Decoder Configuration



- b. Enable **Subtitles**, select **Apply** and close the window.

C

Optional Items

Check with your sales representative for the price and availability of the following item:

- Remote Control

Remote Control Operation



RECORD	Press to start or stop manual recording.
PTZ	Press to control PTZ operation.
SEARCH	Press to go to the search menu.
SEQUENCE	Press to start auto sequencing of screen in full screen mode.
SELECT	Press to select desired menu item, to store a setup value in the menu, or to display quad view.
SETUP	Press to launch the setup menu.
ESC	Press to return to the previous menu screen.
F/REW	Press to jump/step 60 seconds backward in playback mode.
PLAY/PAUSE	Press to play or pause a video in playback mode.
F/ADV	Press to jump/step 60 seconds forward in playback mode.
REW	Press to rewind the footage at 1x, 2x, 4x, 8x, and 16x speeds in playback mode.
ARCH	Press to start operation involving archiving.
FF	Press to fast forward the footage at 1x, 2x, 4x, 8x, and 16x speeds in playback mode.
▲	Press to select camera 1 or password digit 1.
▶	Press to select camera 2 or password digit 2.
▼	Press to select camera 3 or password digit 3.



Press to select camera 4 or password digit 4.

1-9

Press to select the remote unit.

Configuring Multiple Units for Remote Control

To configure multiple units for different remote control IDs, see *REMOTE CONTROLLER ID*, page 19. The selected remote unit will display the remote control icon on the monitor ()

Specifications

Table D-1 Technical Specifications

Video

Signal Format:	NTSC or PAL
Video Input:	Composite: 4-channel, 1.0 V P-P, 75 Ω , BNC
Monitor Outputs:	Composite: 1-channel, 1.0 V P-P, 75 Ω , BNC VGA: 1-channel
Video Resolution:	NTSC: Quad 360 x 240, Full screen 720 x 480 PAL: Quad 360 x 288, Full screen 720 x 576
Compression Algorithm:	MPEG-4
Playback/Record Speed (frames per second):	NTSC: Quad 120 IPS, Full screen 30 IPS/4-ch PAL: Quad 100 IPS, Full screen 25 IPS/4-ch
Still Image Capture:	NTSC: Quad 360 x 240, Full screen 720 x 480 PAL: Quad 360 x 288, Full screen 720 x 576

Inputs, Outputs

Alarm Input:	4 Sensor In (N/O, N/C selectable)
Alarm Output:	1 Internal Relay, Rated Load 0.5 A @ 30 VAC or 1 A @ 30 VDC
Network Connectivity:	ADSL, LAN / Dynamic IP Support 1 10/100-base T Ethernet
Audio Input:	4 Lines In, Line level input (RCA)
Audio Output:	1 Line Out (RCA)

Connectors

Video Input:	Composite: 4-channel BNC
Monitor Output:	Composite: 1-channel BNC VGA: 1-channel
Audio In:	RCA
Audio Out:	RCA
Ethernet Port:	RJ-45, 10/100 Base
RS232C Serial Port:	9-pin D type (Engineering use only)

Table D-1 Technical Specifications (Cont'd)

Archive:	USB Port
Storage	
Primary Storage:	Max 1 hard disk, parallel IDE
General	
Dimensions (W x H x D):	13.78 in. x 2.83 in. x 10.24 in. (350 mm x 72 mm x 260 mm)
Unit Weight:	7.05 lb. (3.0 kg)
Operating Temperature:	32°F to 104°F (0°C to 40°C)
Storage Temperature:	14°F to 122°F (-10°C to 50°C)
Operating Humidity:	0 to 90% (non-condensing)
Power:	100 to 240 VAC, 50/60 Hz, 1.5 A, External Adapter
Input Voltage:	12 VDC, 5 A
Power Consumption:	Normal 18W (12 V, 1.5 A)
Note Specifications are subject to change without notice.	

Honeywell Video Systems (Head Office)

2700 Blankenbaker Pkwy, Suite 150
Louisville, KY 40299, USA
www.honeywellvideo.com
☎ +1.800.796.2288

Honeywell Security Australia Pty Ltd.

Unit 5, Riverside Centre, 24-28 River Road West
Parramatta, NSW 2150, Australia
www.ademco.com.au
☎ +61.2.8837.9300

Honeywell Security Asia Pacific

33/F Tower A, City Center, 100 Zun Yi Road
Shanghai 200051, China
www.security.honeywell.com/cn
☎ +86 21.2527.4568

Honeywell Security Asia

Flat A, 16/F, CDW Building, 388 Castle Peak Rd.
Tsuen Wan, N.T., Hong Kong
www.security.honeywell.com/hk
☎ +852.2405.2323

Honeywell Security France

Parc Gutenberg, 8, Voie La Cardon
91120, Palaiseau, France
www.honeywell.com/security/fr
☎ +33.01.64.53.80.40

Honeywell Security Italia SpA

Via Treviso 2 / 4
31020 San Vendemiano
Treviso, Italy
www.honeywell.com/security/it
☎ +39.04.38.36.51

Honeywell Security España

Mijancas 1. 3^a Planta
P. Ind. Las Mercedes
28022 Madrid, Spain
www.security.honeywell.com/es
☎ +34.902.667.800

Honeywell Video Systems Northern Europe

Netwerk 121
1446 WV Purmerend, The Netherlands
www.SecurityHouse.nl
☎ +31.299.410.200

Honeywell Video Systems UK Ltd.

Aston Fields Road, Whitehouse Ind Est
Runcorn, Cheshire, WA7 3DL, UK
www.honeywellvideo.com
☎ +0844 8000 235

Honeywell Security South Africa

Unit 6 Galaxy Park, 17 Galaxy Avenue
Linbro Park, P.O. Box 59904
2100 Kengray, Johannesburg, South Africa
www.honeywell.co.za
☎ +27.11.574.2500

Honeywell Security Deutschland

Johannes-Mauthe-Straße 14
D-72458 Albstadt, Germany
www.honeywell.com/security/de
☎ +49.74 31.8 01.0

Honeywell Security Poland

Chmielewskiego 22a, 70-028
Szczecin, Polska
www.ultrak.pl
☎ +48.91.485.40.60

Honeywell Security Czech Republic

Havránkova 33, Brno
Dolní Heršpice, 619 00, Czech Republic
www.olympto.cz
☎ +420.543.558.111

Honeywell Security Slovakia Republic

Vajnorská 142, 83104 Bratislava
Slovakia
www.olympto.sk
☎ +421.2.444.54.660

Honeywell

Video Systems

www.honeywellvideo.com

+1.800.796.CCTV (North America only)

HVSsupport@honeywell.com

© 2006 Honeywell International Inc. All rights reserved. No part of this publication may be reproduced by any means without written permission from Honeywell Video Systems. The information in this publication is believed to be accurate in all respects. However, Honeywell Video Systems cannot assume responsibility for any consequences resulting from the use thereof. The information contained herein is subject to change without notice. Revisions or new editions to this publication may be issued to incorporate such changes.